

Revision History				
Rev	ECN #	Approved Date	Approved by	Notes
N/A	N/A	N/A	N/A	N/A

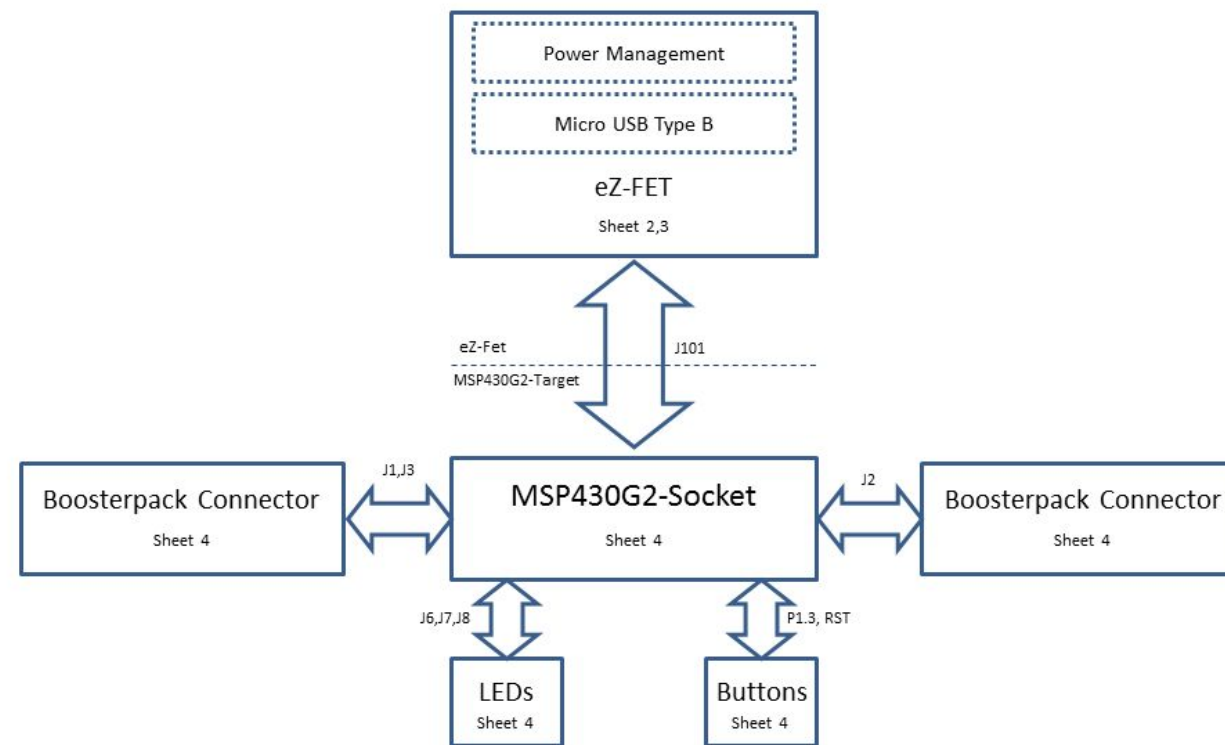

Texas Instruments and/or its licensors do not warrant the accuracy or completeness of this specification or any information contained therein. Texas Instruments and/or its licensors do not warrant that this design will meet the specifications, will be suitable for your application or fit for any particular purpose, or will operate in an implementation. Texas Instruments and/or its licensors do not warrant that the design is production worthy. You should completely validate and test your design implementation to confirm the system functionality for your application.

Orderable: <a href="#">MSP-EXP430G2ET</a>	Designed for: <a href="#">Public Release</a>	Mod. Date: 11/16/2017
TID #: N/A	Project Title: <a href="#">MSP-EXP430G2ET Launchpad</a>	
Number: <a href="#">MCU021</a>	Rev: 1.0	Sheet Title: <a href="#">Block Diagram</a>
SVN Rev: <a href="#">Version control disabled</a>	Assembly Variant: 001	Sheet: 1 of 5
Drawn By:	File: <a href="#">MCU021_V1.0_MSP-EXP430G2ET_CoverSheet.dwg</a>	Sheet: 1 of 5
Engineer: <a href="#">Michael Weber</a>	Contact: <a href="http://www.ti.com/support">http://www.ti.com/support</a>	



# Host MCU for Emulation

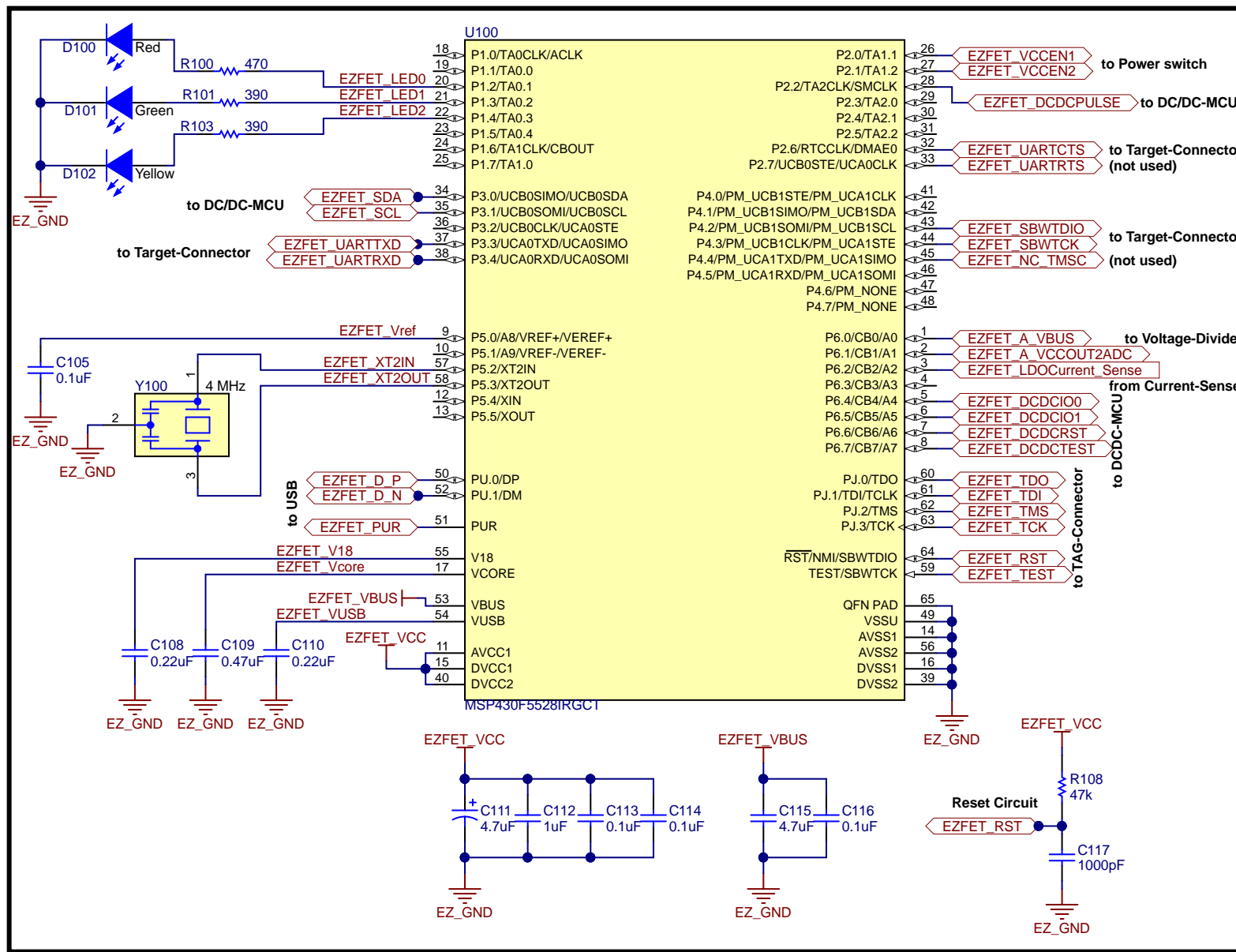

# 3.3V Power (EZFET\_VCC)

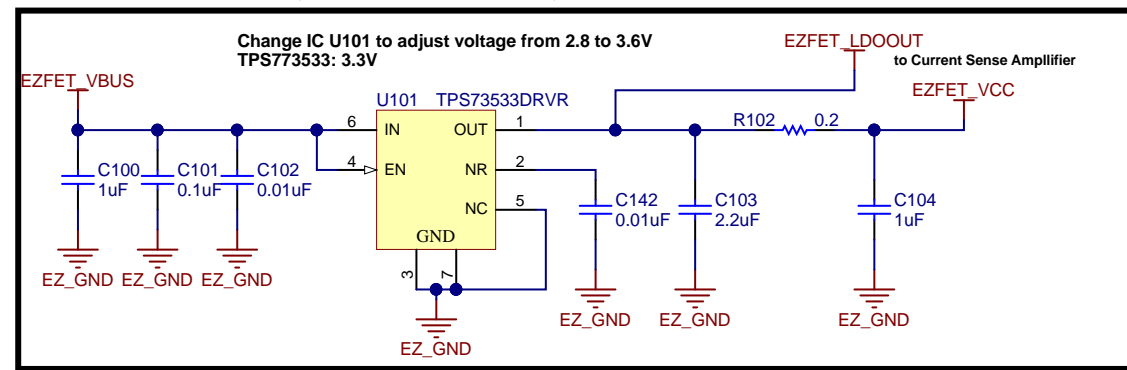

# Target Connector

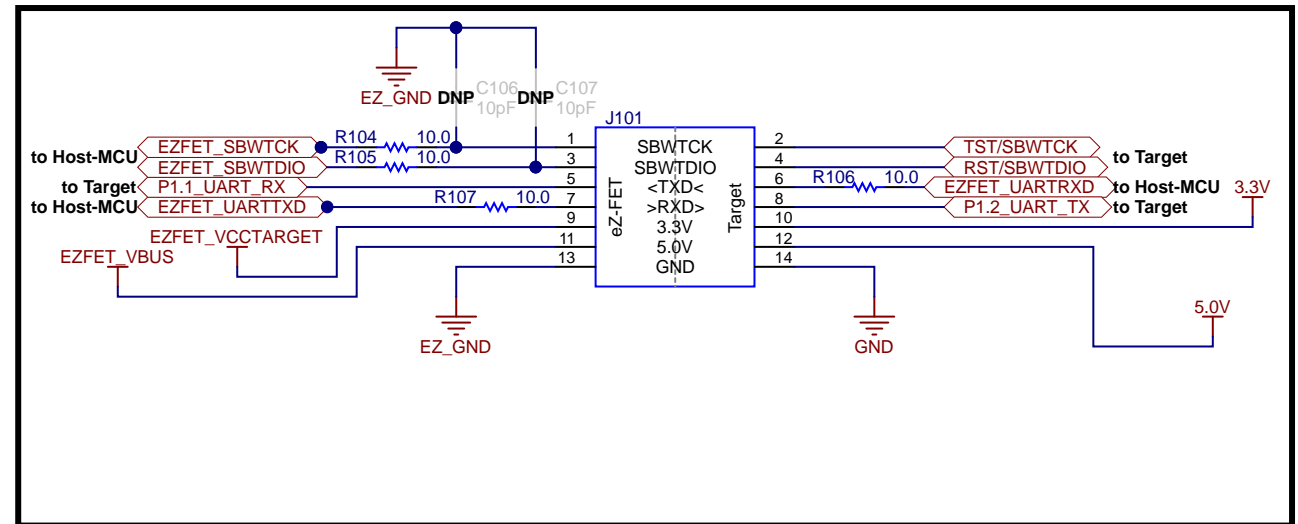

# Current Sense Amplifier

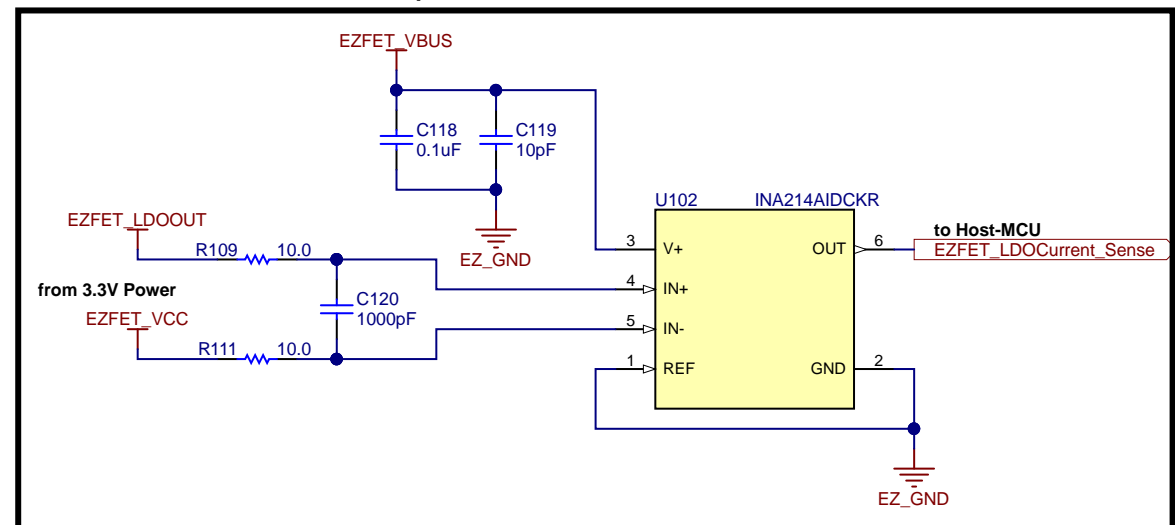

# USB-Interface

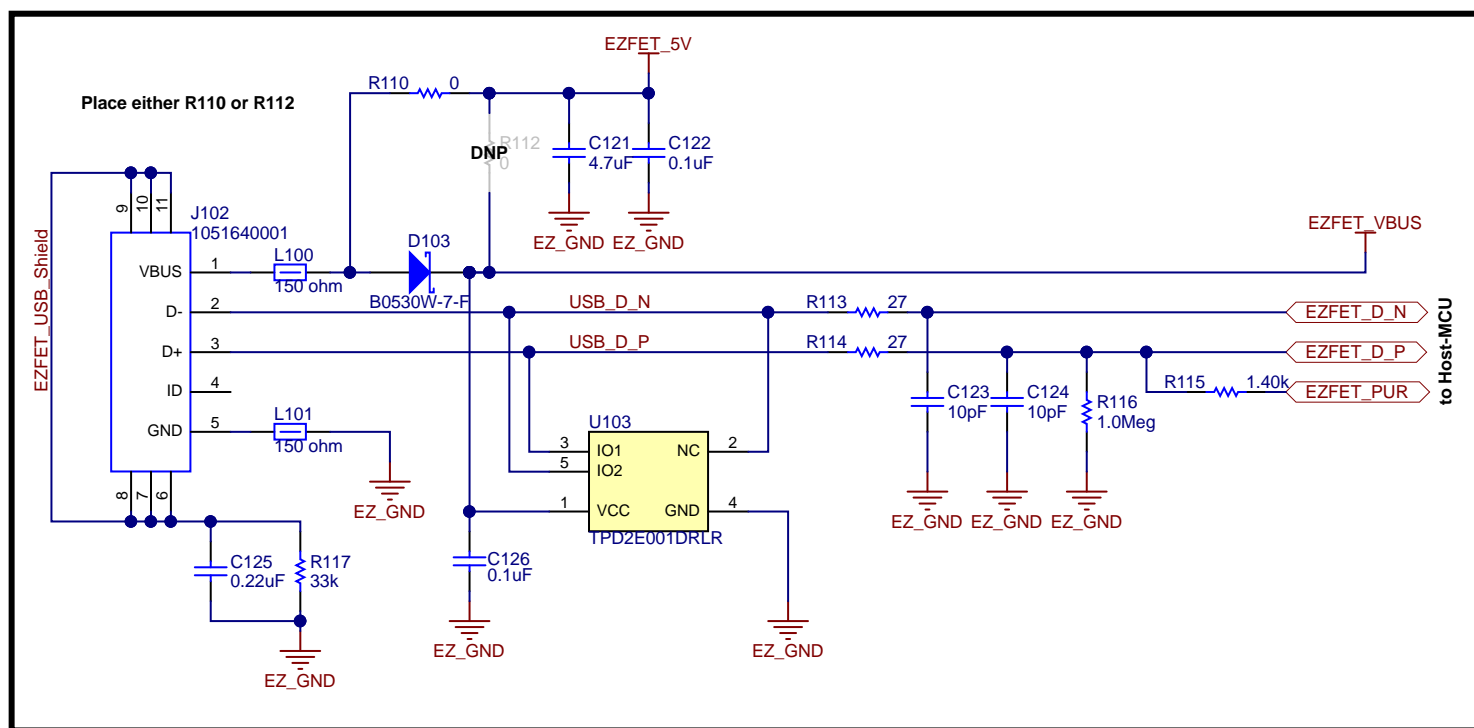

# TAG-Connector (Host Debug)

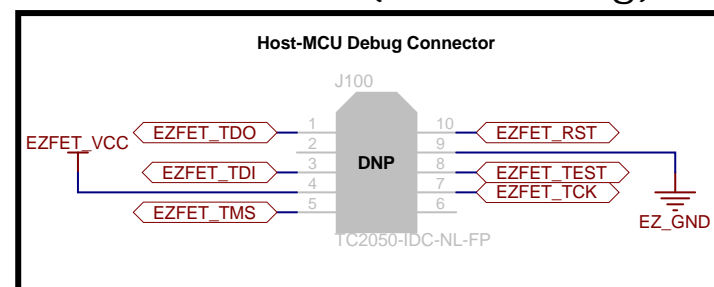

Texas Instruments and/or its licensors do not warrant the accuracy or completeness of this specification or any information contained therein. Texas Instruments and/or its licensors do not warrant that this design will meet the specifications, will be suitable for your application or fit for any particular purpose, or will operate in an implementation. Texas Instruments and/or its licensors do not warrant that the design is production worthy. You should completely validate and test your design implementation to confirm the system functionality for your application.

Orderable: MSP-EXP430G2ET	Designed for: Public Release	Mod. Date: 11/3/2017
TID #: N/A	Project Title: MSP-EXP430G2ET Launchpad	
Number: MCU021	Rev: 1.0	Sheet Title: ez-FET: Host-MCU, USB, Power
SVN Rev: Version control disabled	Assembly Variant: 001	Sheet: 2 of 5
Drawn By:	File: MCU021_V1.0_MSP-EXP430G2ET_ezFET_HostMCU_Rev03	
Engineer: Michael Weber	Contact: http://www.ti.com/support	

## DCDC-MCU

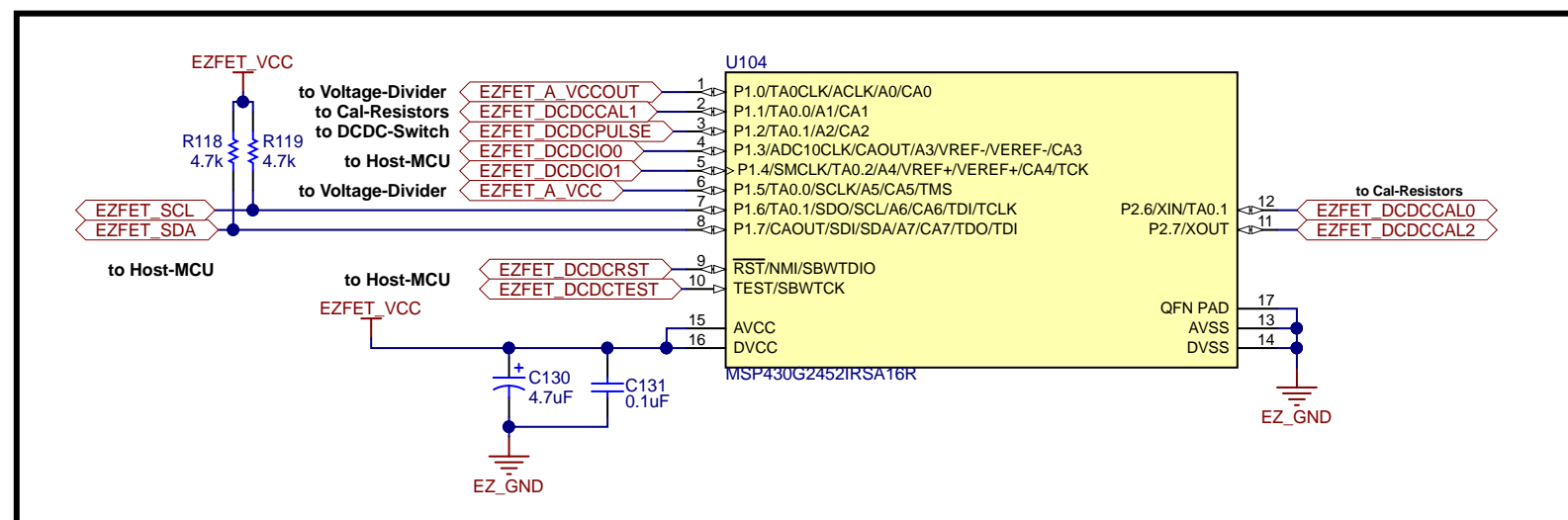

## DCDC-Switch

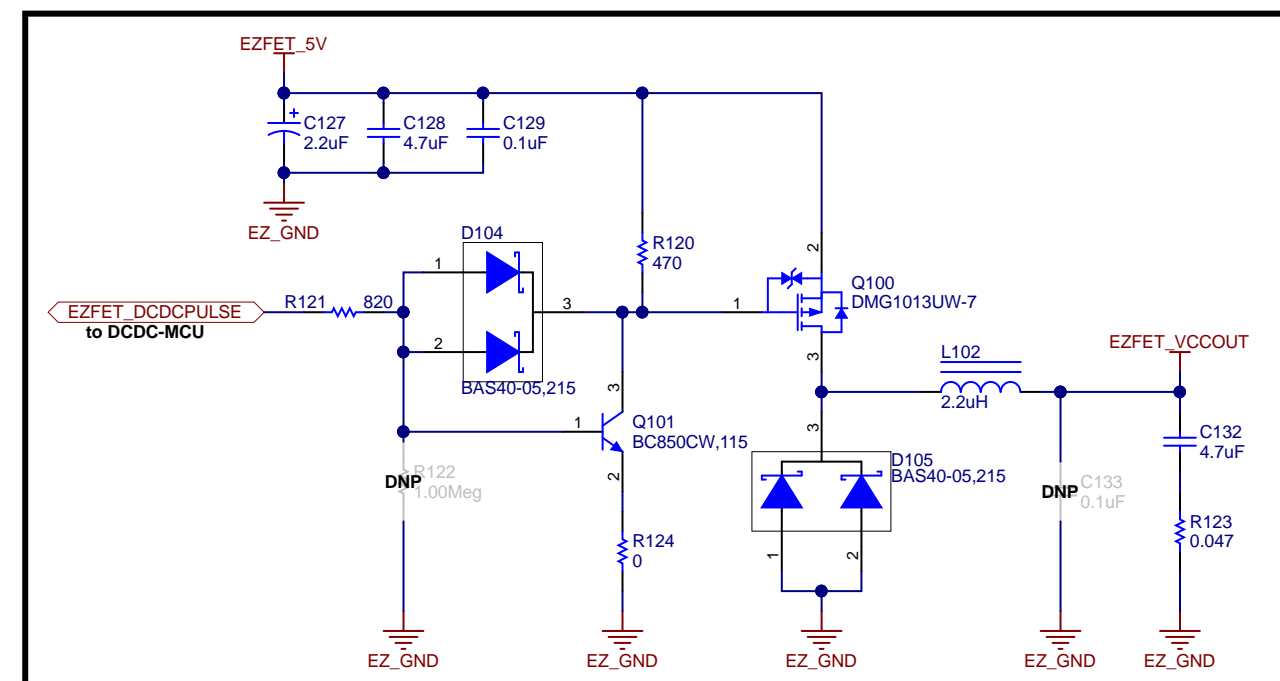

## Voltage Dividers

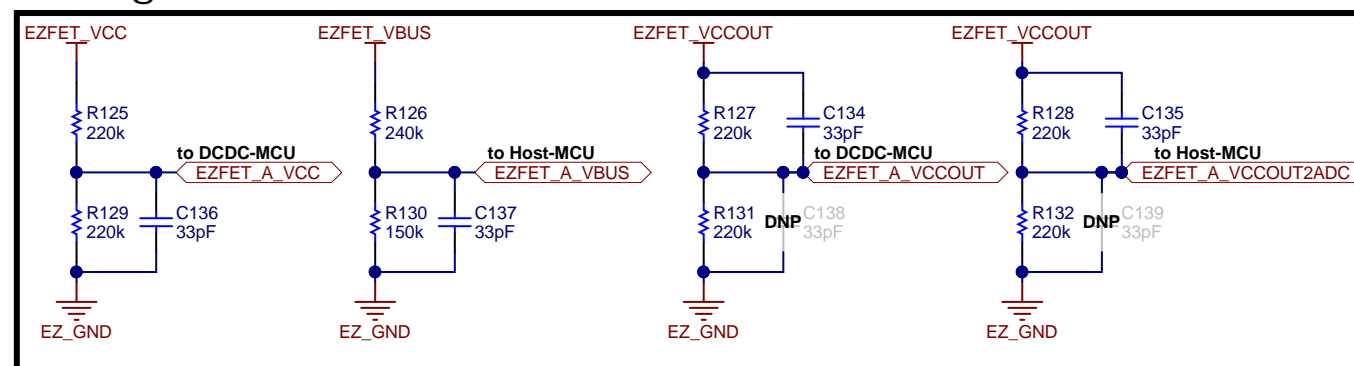

## Power Switch

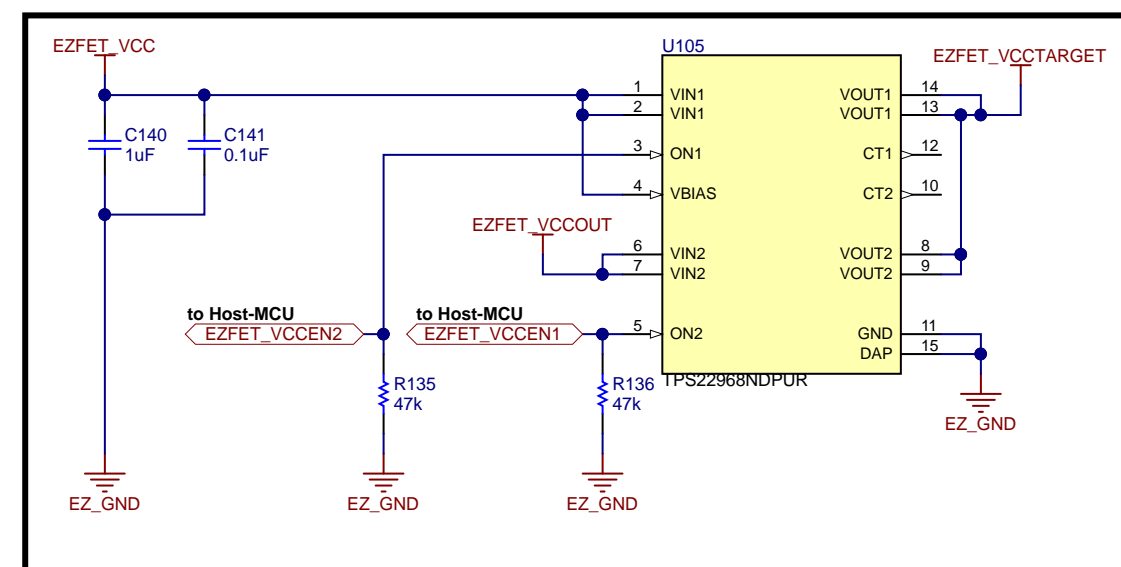

## DCDC-Calibration Resistors

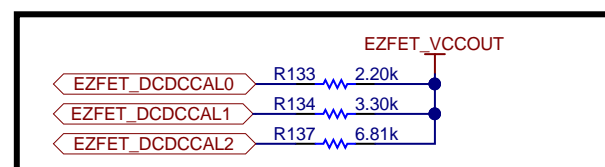

## Software-controlled DCDC converter

Energy measurement method protected under U.S. Patent Application 13/329,073 and subsequent patent applications.

Texas Instruments and/or its licensors do not warrant the accuracy or completeness of this specification or any information contained therein. Texas Instruments and/or its licensors do not warrant that this design will meet the specifications, will be suitable for your application or fit for any particular purpose, or will operate in an implementation. Texas Instruments and/or its licensors do not warrant that the design is production worthy. You should completely validate and test your design implementation to confirm the system functionality for your application.

# MSP430G2xxx Target

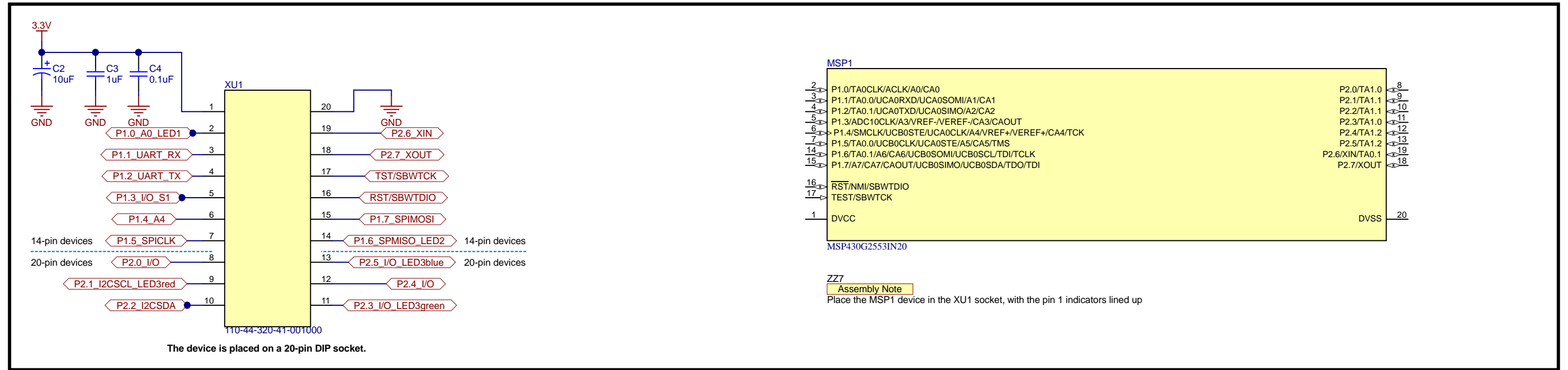

## Pushbuttons

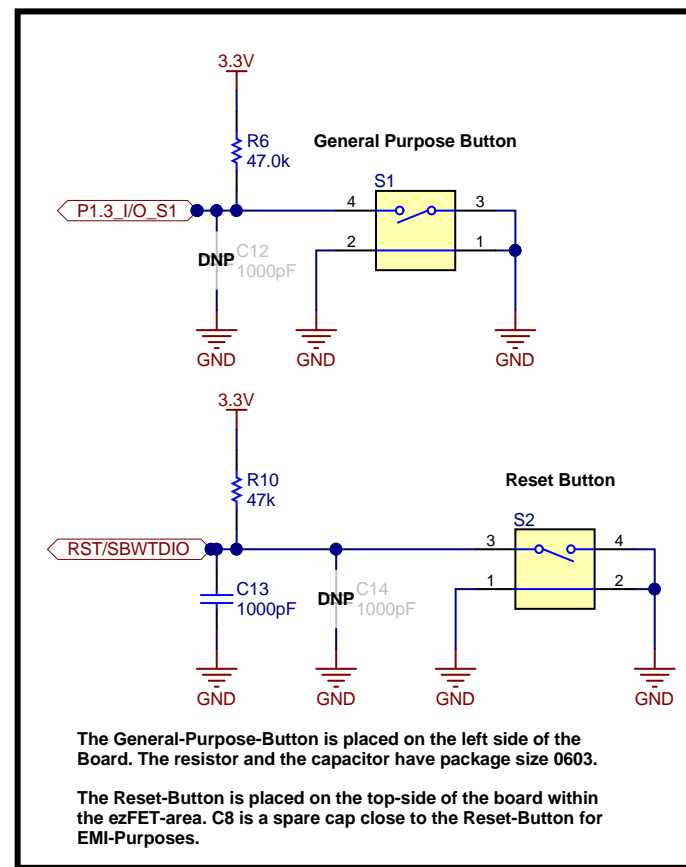

## LEDs

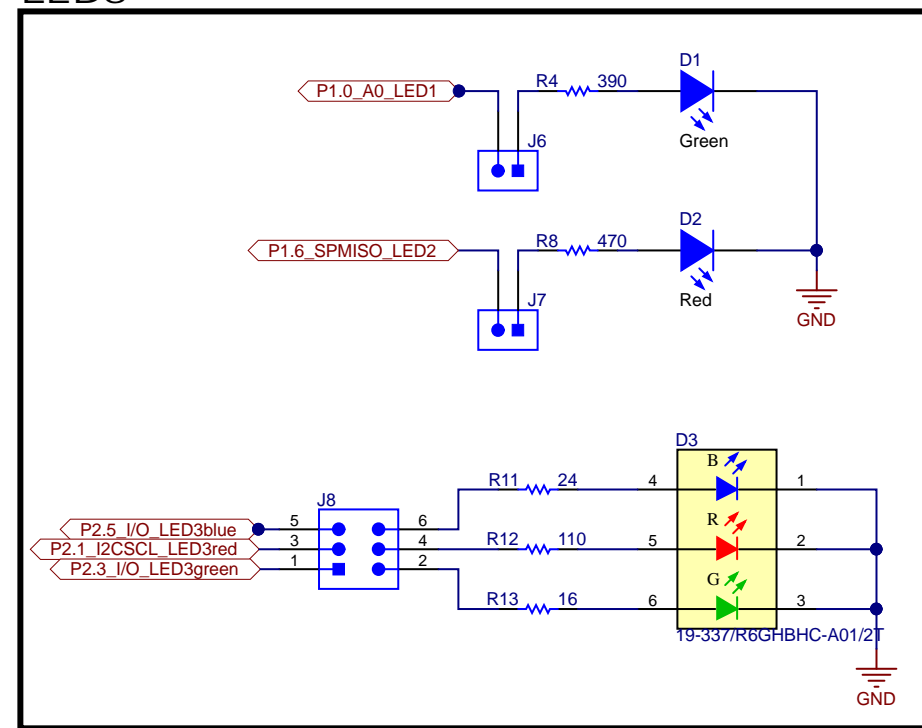

## Crystal Selection

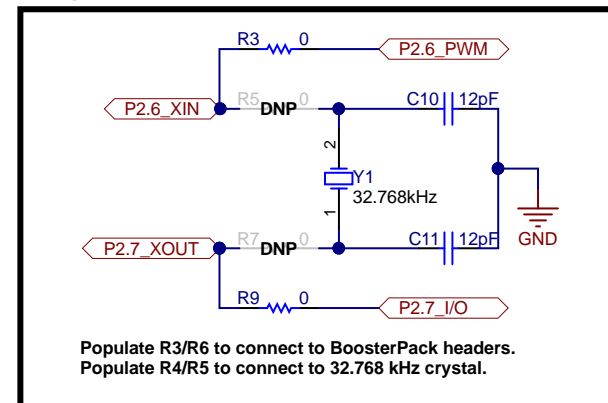

## BoosterPack Headers

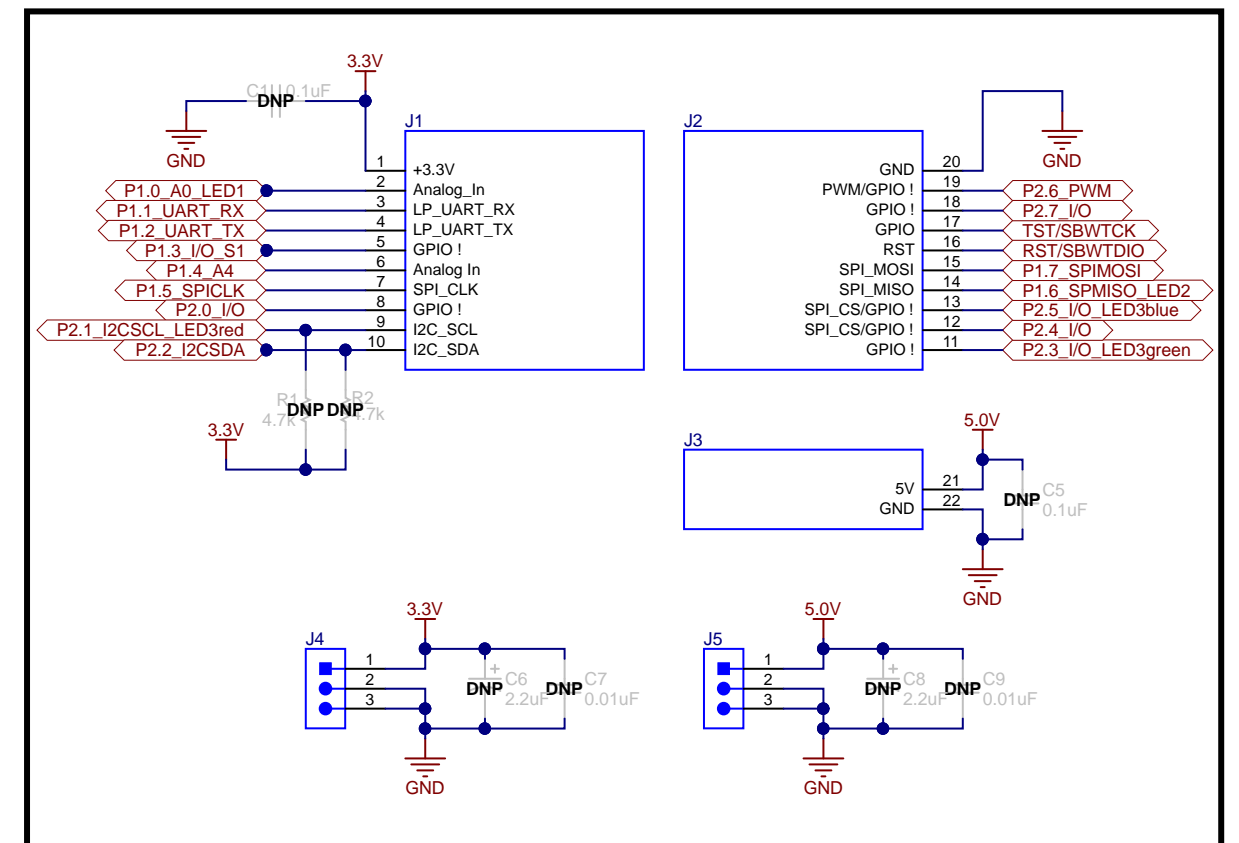



PCB LOGO  
ESD Logo1

PCB LOGO  
FCC disclaimer

PCB LOGO  
RoHS Logo1

PCB LOGO  
TI Logo 1

PCB LOGO  
Texas Instruments



PCB Number: MCU021  
PCB Rev: 1.0

USB1  
MECH  
AK67421-0.3

ZZ2  
Assembly Note  
These assemblies are ESD sensitive, ESD precautions shall be observed.

ZZ3  
Assembly Note  
These assemblies must be clean and free from flux and all contaminants. Use of no clean flux is not acceptable.

ZZ4  
Assembly Note  
These assemblies must comply with workmanship standards IPC-A-610 Class 2, unless otherwise specified.

ZZ6  
Assembly Note  
Place a click-in Standoff (MAE-10, KangYang) in hole MH1/MH2. Parameters for Standoffs were manually adapted for BOM generation.

### Shunts for Target-Connector

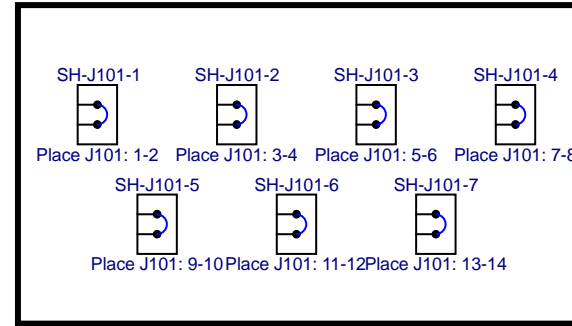

### Shunts for LEDs

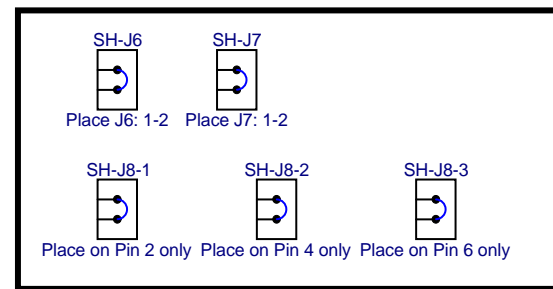

ZZ5  
Assembly Note  
Place the shunts for RGB-LEDs (SH-J8-1, SH-8-2 and SH-J8-3) only on the right pins of J8

### Standoff

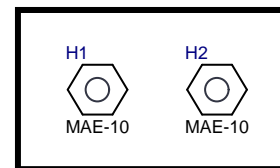

Texas Instruments and/or its licensors do not warrant the accuracy or completeness of this specification or any information contained therein. Texas Instruments and/or its licensors do not warrant that this design will meet the specifications, will be suitable for your application or fit for any particular purpose, or will operate in an implementation. Texas Instruments and/or its licensors do not warrant that the design is production worthy. You should completely validate and test your design implementation to confirm the system functionality for your application.

Orderable: MSP-EXP430G2ET	Designed for: Public Release	Mod. Date: 11/17/2017
TID #: N/A	Project Title: MSP-EXP430G2ET Launchpad	
Number: MCU021	Rev: 1.0	Sheet Title: Labels, Mechanical Hardware, Shunts, Misc.
SVN Rev: Version control disabled	Assembly Variant: 001	Sheet: 5 of 5
Drawn By:	File: MCU021_V1.0_MSP-EXP430G2ET_Hardware_Sht003	
Engineer: Michael Weber	Contact: http://www.ti.com/support	

